

i116 V.B2

Product manual

ingenia

i116 – Product manual

Copyright and trademarks

Copyright © 2010 INGENIA-CAT, S.L.

Scope

This document applies to i116 motion controller in its hardware version B2.

Disclaimers and limitations of liability

Except in cases specifically indicated in other agreements and **INGENIA-CAT**, this product and its documentation are provided “as is”, with no warranties or conditions of any type, whether express or implied, including, but not limited to the implied warranties or conditions of merchantability, fitness for a particular purpose or non-infringement.

INGENIA-CAT rejects all liability for errors or omissions in the information or the product or in other documents mentioned in this document.

INGENIA-CAT shall in no event be liable for any incidental, accidental, indirect or consequential damages (including but not limited to those resulting from: (1) dependency of equipment presented, (2) costs or substituting goods, (3) impossibility of use, loss of profit or data, (4) delays or interruptions to business operations (5) and any other theoretical liability that may arise as a consequence of the use or performance of information, irrespective of whether **INGENIA-CAT** has been notified that said damage may occur.

Some countries do not allow the limitation or exclusion of liability for accidental or consequential damages, meaning that the limits or exclusions stated above may not be valid in some cases.

This document may contain technical or other types of inaccuracies. This information changes periodically.

Contents

Main features	2
Areas of use:.....	2
Specifications:.....	3
Description.....	5
Output driver interface	5
Communication interfaces	7
Encoder interface.....	13
General purpose digital inputs/outputs	15
Analog-to-digital converter interface (ADC)	18
Digital-to-analog converter interface (DAC)	19
Connectors	21

Icons

Icons that the reader may encounter in this manual are shown below, together with their meanings.



Additional information

Provides the user with tips, tricks and other useful data.



Warning

Provides the user with important information. Ignoring this warning may cause the device not to work properly.



Critical warning

Provides the user with critical information. Ignoring this critical warning may cause damage to the device.

This chapter outlines the main features and specifications of i116

Summarized below is a functional block diagram for i116 motion controller and its main features and areas of use.

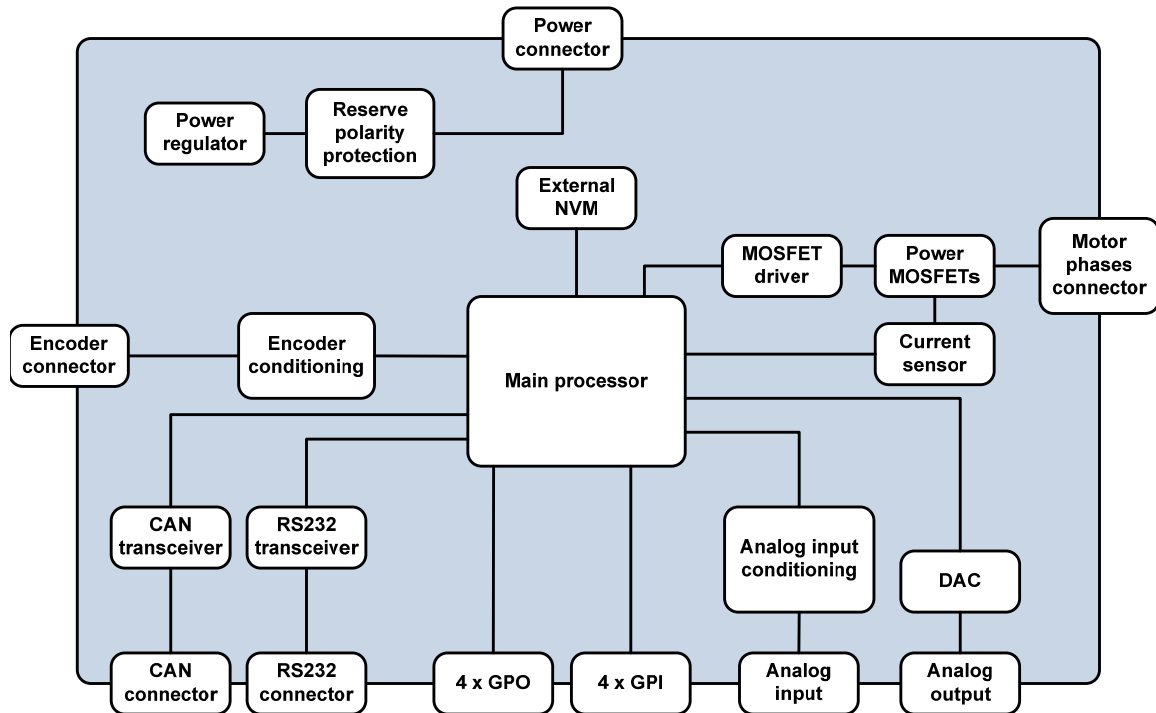

Figure 1: Block diagram of the system

Areas of use:

- CNC machinery, milling, welding, processing, etc.
- Advanced robotic systems (personal, service, special robots, etc.)
- Automotive applications
- Avionics applications
- Tracking systems
- Automation/Industrial systems
- Cutting, pressing and tightening tools, etc
- High precision linear or angular positioning systems.
- Instrumentation, measurement, positioning, medical and inspection systems
- Haptic/Force feedback systems
- Electronic gearing systems

Specifications:

Description	Slave or stand alone motion controller
Operating modes	Profiled position, Profiled velocity, Profiled torque, Interpolated position and Homing
Motor types	Permanent magnet synchronous motor (BLAC) and Brushed DC
Modulation and control	BLAC: Sinusoidal control with SVPWM modulation. DC: PWM modulation
Filter algorithm	PID+FFV+FFA for position PID+FFA for velocity PI using FOC
Max. servo loop rate	10KHz for current 5KHZ for the position and velocity
Trajectory generator	Trapezoidal profiles
Servo position feedback	Incremental encoder with index
Encoder and index input	Differential or single-ended
Encoder supply voltage	5VDC
Encoder count rate	2Mcounts per second
Output	PWM motor drive, $2A_{RMS}$ continuous and $4A_{RMS}$ peaks (1 second) at 48VDC Max.
PWM freq.	39KHz approximately
Position range	32 bits
Velocity range	32 bits
Acceleration range	32 bits
General purpose I/O	4 TTL compatible digital inputs and 4 TTL compatible digital outputs
Analog inputs	One channel with 10 bit resolution 0 – 5V
Analog outputs	0 – 5V 10 bit resolution output or 0 – 10V 16 bit resolution output
Communication interfaces	CAN interface up to 1Mbps RS-232 serial interface up to 115200bps (daisy chain option)
Supply voltage	24 – 48V
Motor supply voltage	24 – 48V
Protections	Polarity inversion and overcurrent (peak and I^2T)
Other features	Aux. supply output 5V – 150mA.

Dimensions	Approx. 100mm long by 76mm wide by 20mm thick
Weight	72gr.

Table 1: Specifications

This chapter shows a description of the different functional blocks.

Output driver interface

The i116 output driver is a PWM switching amplifier capable of supplying $2A_{RMS}$ continuous and $4A_{RMS}$ peak (for 1 second max.) at a switching frequency of approximately 39KHz.

This driver is intended for driving brushless AC (BLAC) and brushed DC motors and actuators. Depending on the motor type, the connection to the board must be done in a different way. Figure 2 and Figure 3 show how to connect a BLAC and a DC motor to the i116 board:

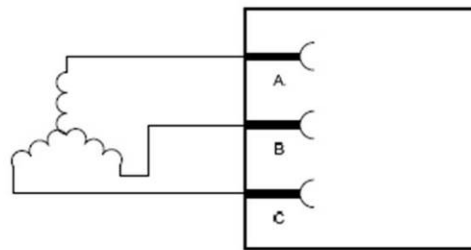

Figure 2: Brushless motor connection diagram

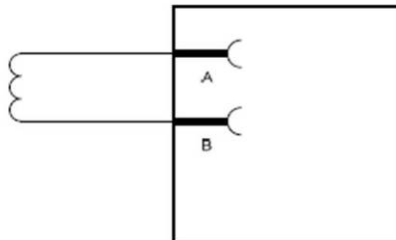

Figure 3: Brushed DC motor connection diagram

An over current protection mechanism is included in the board for security. Maximum allowed currents are $2A_{RMS}$ continuous and $4A_{RMS}$ peaks (for less than one second).



The power phase can reach temperatures of more than 100°C. Take due precaution before exposing this area to human contact.

The motor connector (shared with the power supply) is marked as J5 in the board. The pin out of this connector is shown in Table 2, and the voltage and current levels in Table 3 and Table 4 respectively:

	Pin ID	Pin	Type	Description
J5 (Power supply and motor connector)	1	+Vbus	Input	Bus voltage (24 – 48VDC)
	2	GND	Input	Ground
	3	A	Output	DC motor : DC+ BLAC motor : Phase A
	4	B	Output	DC motor : DC- BLAC motor : Phase B
	5	C	Output	BLAC motor : Phase C
	6	N.C.	-	-

Table 2: Power / Phases connector pinout

Pin name	V _{min}	V _{typ}	V _{max}	Units
A	-0.3	0 - 48	60	V
B	-0.3	0 - 48	60	V
C	-0.3	0 - 48	60	V

Table 3: Phase pin voltage levels

Pin name	I _{min}	I _{typ}	I _{max}	Units
A	-	2	4	A _{RMS}
B	-	2	4	A _{RMS}
C	-	2	4	A _{RMS}

Table 4: Phase pin currents

Communication interfaces

i116 is provided with two different communication interfaces:

- CAN interface
- RS-232 serial interface

CAN interface

The i116 can communicate with a host computer via CAN interface. The CAN-Bus (Controller Area Network-Bus) is a serial communication protocol developed by Bosch for exchanging information between electronic control units on automobiles.

This system makes it possible to share a great amount of information between the nodes or control units appended to the system, which causes a major reduction in both the sensors used and the quantity of cables in the electrical installation.

The baud rate is user selectable from 125Kbps to 1Mbps (default value). Figure 4 shows how to connect one controller to the host, and Figure 5 shows a multiple controller configuration.

Bus termination resistors (120Ω between CANL and CANH at both ends of the bus) is necessary for correct operation of the CAN bus (mainly for long distances and high baud rates).

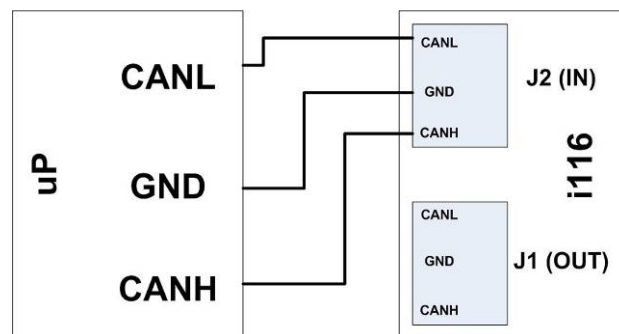

Figure 4: CAN interface connection

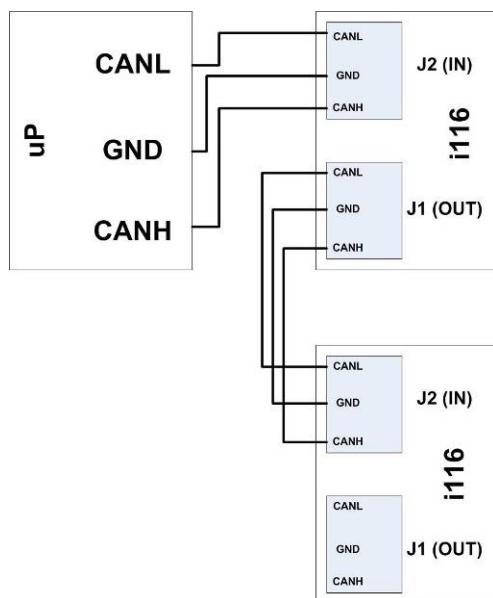

Figure 5: Multiple node connection

When using CAN interface, jumpers located near connector J1 must be placed (see Figure 6).

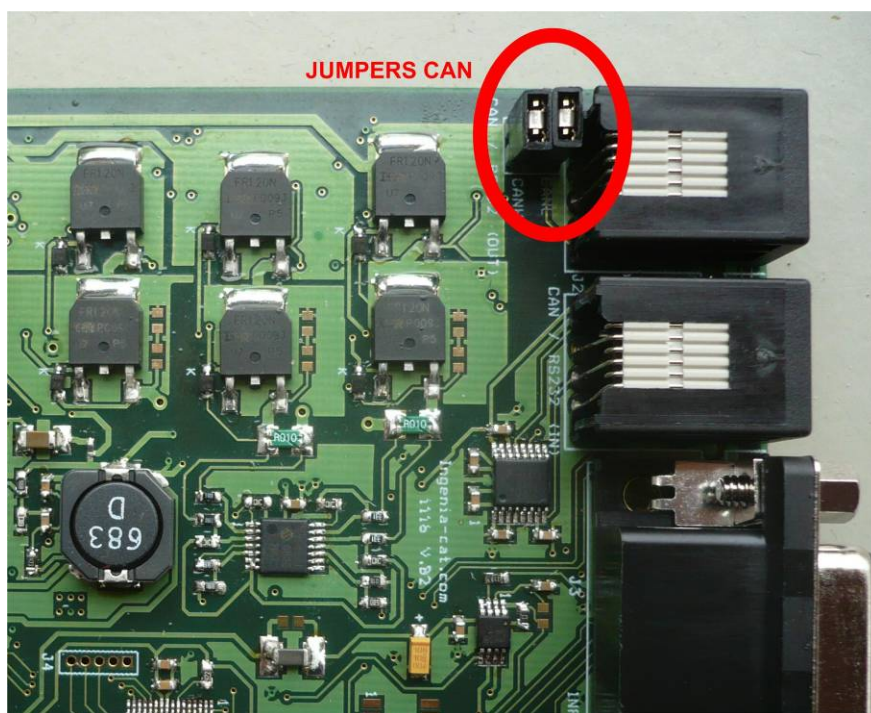

Figure 6: For CAN communications, jumpers must be placed

i116 is provided with two CAN connectors to simplify the cabling in multi-node configuration. In this mode, the previous node on the bus could be connected to J2 connector (IN), and next node on bus could be connected to J1 (OUT).

Table 5 and Table 6 show the pin out of these connectors:

	Pin ID	Pin	Type	Description
J1 (RS-232 and CAN OUTPUT connector)	1	CANH	Input / Output	CAN high
	2	CANL	Input / Output	CAN low
	3	N.C.	-	-
	4	232 TX	Output	RS-232 transmission
	5	GND	Output	Ground
	6	N.C.	-	-

Table 5: J1 connector pin out

	Pin ID	Pin	Type	Description
J2 (RS-232 and CAN INPUT connector)	1	CANH	Input / Output	CAN high
	2	CANL	Input / Output	CAN low
	3	232 RX	Input	RS-232 reception
	4	232 TX	Output	RS-232 transmission
	5	GND	Output	Ground
	6	N.C.	-	-

Table 6: J2 connector pin out

The table below shows the i116 motion controller pins related to CAN communications and their voltage ranges.

Pin	V _{min}	V _{typ}	V _{max}	Units
CANH	-7.5	-5.5	12.5	V
CANL	-7.5	-5.5	12.5	V

Table 7: CAN pins voltage range

RS-232 serial interface

RS-232 (also known as Electronic Industries Alliance RS-232C) is an interface that assigns a rule for the serial interchange of binary data between a DTE (Data Terminal Equipment) and a DCE (Data Communication Equipment), even though other situations exist in which interface RS-232 is also used.

This interface is designed for short distances, about 15m or less, and for low communication speeds of no more than 20KB. In spite of this, it is very often used at higher speeds with acceptable results. The interface can work in asynchronous or synchronous communication and simplex, half duplex or full duplex channel types.

The baud rate is user selectable between 9600bps and 115200bps (default value). Figure 7 shows how to connect one controller to the host, and Figure 8 shows multiple controllers in a daisy-chain configuration.

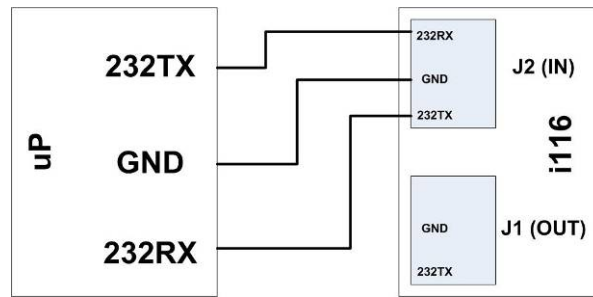

Figure 7: RS-232 interface

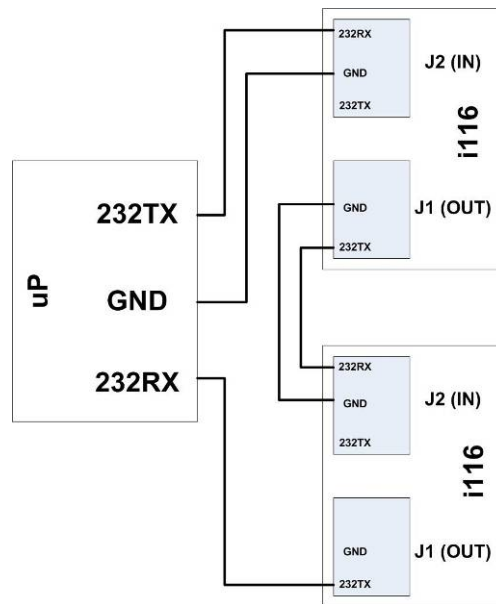

Figure 8: Daisy chain configuration

When using RS232 interface, jumpers located near connector J1 must be taken off (see Figure 9).

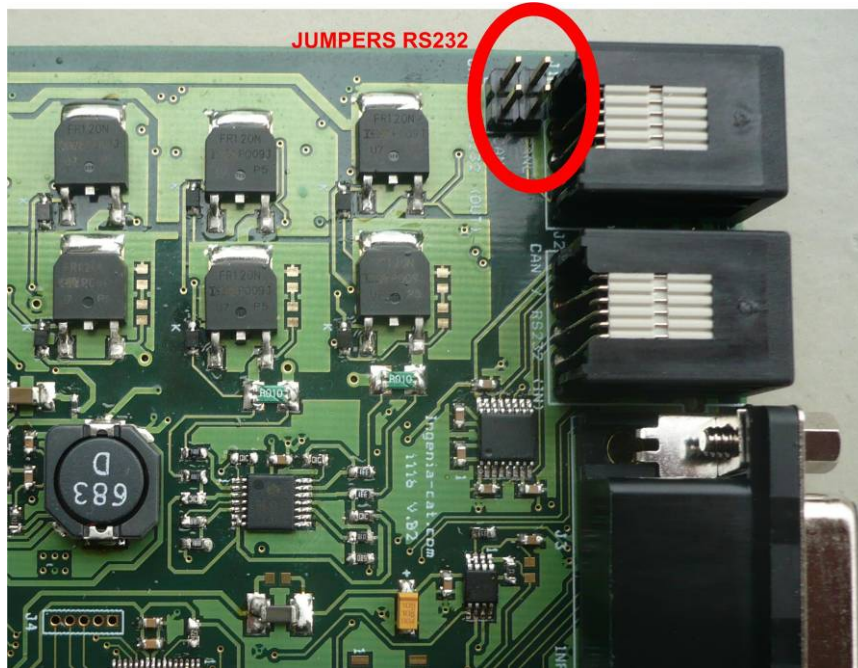

Figure 9: For RS232 communications, jumpers must be taken off

i116 is provided with two RS-232 connectors to allow daisy-chain configuration. In daisy-chain mode, the previous node on the bus could be connected to J2 connector (IN), and next node on bus could be connected to J1 (OUT).

Table 8 and Table 9 show the pin out of these connectors.

	Pin ID	Pin	Type	Description
J1 (RS-232 and CAN OUTPUT connector)	1	CANH	Input / Output	CAN high
	2	CANL	Input / Output	CAN low
	3	N.C.	-	-
	4	232 TX	Output	RS-232 transmission
	5	GND	Output	Ground
	6	N.C.	-	-

Table 8: J1 connector pinout

	Pin ID	Pin	Type	Description
J2 (RS-232 and CAN INPUT connector)	1	CANH	Input / Output	CAN high
	2	CANL	Input / Output	CAN low
	3	232 RX	Input	RS-232 reception
	4	232 TX	Output	RS-232 transmission
	5	GND	Output	Ground
	6	N.C.	-	-

Table 9: J2 connector pinout

The table below shows the i116 motion controller pins related to RS232 communications and their voltage ranges.

Pin	V _{min}	V _{typ}	V _{max}	Units
232 TX	-13.2	-5...5	13.2	V
232 RX	-25	-5...5	25	V

Table 10: CAN pins voltage range

Encoder interface

The i116 has one differential quadrature encoder interface with optional index signal input.

The high signals (AH, BH and ZH - index) are pulled up to +5VDC with 4K7 resistors, and low signals (AL, BL and ZL) are biased at 2.5VDC with 10K resistors. This arrangement let user to connect both; open collector and totem pole single-ended output encoders, or differential output encoders.

For single ended encoders, only high input signal (AH, BH and ZH) must be used.

Encoder connector is marked as P1 in the board. Table 11 shows the pin out of this connector:

	Pin ID	Pin	Type	Description
P1 (ENCODER connector)	1	AH	Input	Encoder channel A high
	2	ZH	Input	Encoder index high
	3	BH	Input	Encoder channel B high
	4	+V5	Output	5VDC
	5	+V5	Output	5VDC
	6	+V5	Output	5VDC
	7	-	-	-
	8	-	-	-
	9	AL	Input	Encoder channel A low
	10	ZL	Input	Encoder index low
	11	BL	Input	Encoder channel B low
	12	GND	Output	Ground
	13	GND	Output	Ground
	14	-	-	-
	15	-	-	-

Table 11: P1 encoder connector pin out

The table below shows the i116 motion controller pins related to encoder and their voltage ranges.

Pin	V _{min}	V _{typ}	V _{max}	Units
AH, AL	-0.3	0.5	5.6	V
BH, BL	-0.3	0.5	5.6	V
ZH, ZL	-0.3	0.5	5.6	V

Table 12: Encoder pins voltage range

General purpose digital inputs/outputs

i116 is provided with 4 general purpose digital inputs and 4 general purpose digital outputs, all of them TTL compatible.

General purpose inputs

General purpose digital inputs are connected to the main processor through a 1K5 resistor that protects the processor from an over current.

The polarity of GPI is user configurable through its communication interface. Figure 10 illustrates the model of general purpose inputs.

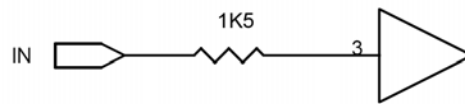

Figure 10: GP input model

General purpose outputs

General purpose digital outputs are driven by a buffer, without any pull up resistor. The polarity of GPO is user configurable through its communication interface. Figure 11 illustrates the model of general purpose outputs.

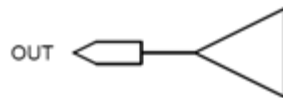

Figure 11: GP output model

Following tables show the pin out of the input/output connector (marked as J3 in the board) and the maximum voltage and current level ranges. GPI, GPO and analog input/outputs share the same connector.

	Pin ID	Pin	Type	Description
J3 (INPUT / OUTPUT connector)	1	-	-	-
	2	-	-	-
	3	GPI 2	Input	General purpose digital input 2
	4	GPI 0	Input	General purpose digital input 0
	5	GND	Output	Ground
	6	ANALOG OUT	Output	DAC output
	7	-	-	-

8	GPO 2	Output	General purpose digital output 2
9	GPO 0	Output	General purpose digital output 0
10	-	-	-
11	-	-	-
12	GPI 3	Input	General purpose digital input 3
13	GPI 1	Input	General purpose digital input 1
14	GND	Output	Ground
15	-	-	-
16	-	-	-
17	GPO 3	Output	General purpose digital output 3
18	GPO 1	Output	General purpose digital output 1
19	+V5	Output	5VDC output
20	+V5	Output	5VDC output
21	+V5	Output	5VDC output
22	+V5	Output	5VDC output
23	GND	Output	Ground
24	ANALOG IN	Input	ADC input
25	-	-	-
26	-	-	-

Table 13: J3 INPUT / OUTPUT connector pin out

Pin	V _{min}	V _{typ}	V _{max}	Units
GPI 0	-0.3	0...5	5.5	V
GPI 1	-0.3	0...5	5.5	V
GPI 2	-0.3	0...5	5.5	V
GPI 3	-0.3	0...5	5.5	V
GPO 0	-0.5	0...5	5.5	V
GPO 1	-0.5	0...5	5.5	V
GPO 2	-0.5	0...5	5.5	V
GPO 3	-0.5	0...5	5.5	V

Table 14: GPIO pins maximum voltage levels

Pin	I_{min}	I_{typ}	I_{max}	Units
GPI 0	-	-	4	mA
GPI 1	-	-	4	mA
GPI 2	-	-	4	mA
GPI 3	-	-	4	mA
GPO 0	-	24	50	mA
GPO 1	-	24	50	mA
GPO 2	-	24	50	mA
GPO 3	-	24	50	mA

Table 15: GPIO maximum current levels

Pin	$V_{IL\ max}$	$V_{IH\ min}$	Units
GPI 0	0.66	2	V
GPI 1	0.66	2	V
GPI 2	0.66	2	V
GPI 3	0.66	2	V

Table 16: Logic levels at input pins

Pin	$V_{OL\ max}$	$V_{OH\ min}$	Units
GPO 0	0.44*	4.76*	V
GPO 1	0.44*	4.76*	V
GPO 2	0.44*	4.76*	V
GPO 3	0.44*	4.76*	V

Table 17: Logic levels at output pins

*Conditions : $I_{OH} = -24mA$, $I_{OL} = 24mA$.

Analog-to-digital converter interface (ADC)

The i116 provides one channel, 10 bit A/D converter interface with a +5 VDC reference and analog ground.

In order to get maximum accuracy, the impedance of the analog source should be less than 16KΩ.

The analog input signal is available in the J3 (INPUT/OUTPUT) connector, pin 24. See Table 13 for more details.

The table below shows the i116 motion controller pin related to analog to digital conversion interface and its voltage range.

Pin	V _{min}	V _{typ}	V _{max}	Units
ANALOG IN	-0.45	0..5	5.4	V

Table 18: Voltage range in Analog input pin

Digital-to-analog converter interface (DAC)

The i116 motor controller provides two options for the digital to analog converter interface:

- One 10 bits DAC, with an output range from 0 to 5V.
- One 16 bits DAC, with an output range from 0 to 10V.

The analog output is located in the J3 (INPUT/OUTPUT) connector, pin number 6. See Table 13 for more details.

The table below shows the i116 motion controller pin related to digital to analog conversion interface and its voltage range for both DAC options.

Pin		V_{min}	V_{typ}	V_{max}	Units
ANALOG OUT	10 bits	-	0...5	-	V
ANALOG OUT	16 bits	-	0...10	-	V

Table 19: Voltage level at Analog out pin

These two converters are NOT available at the same time. The selection of the DAC used is done by soldering a 0Ω resistance in the appropriate place (see Figure 12 and Figure 13).

i116 board comes with a default DAC selection of 10bits.

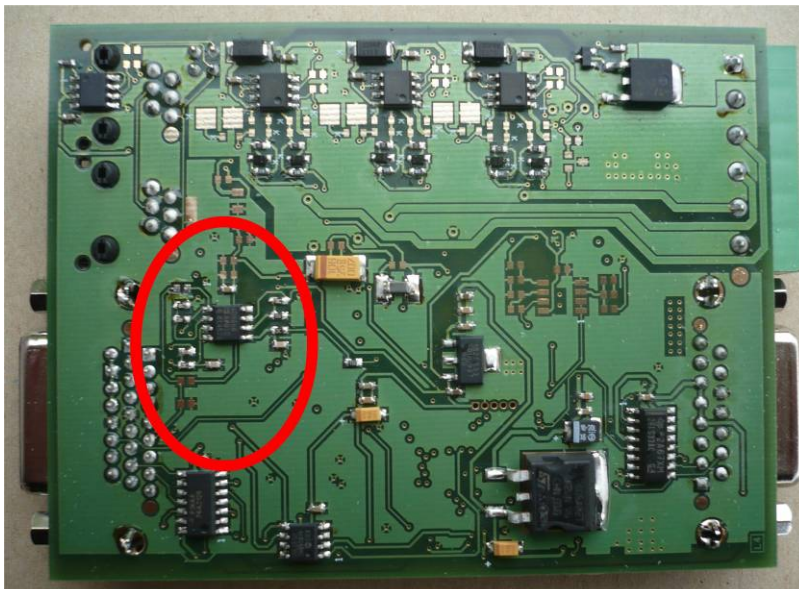
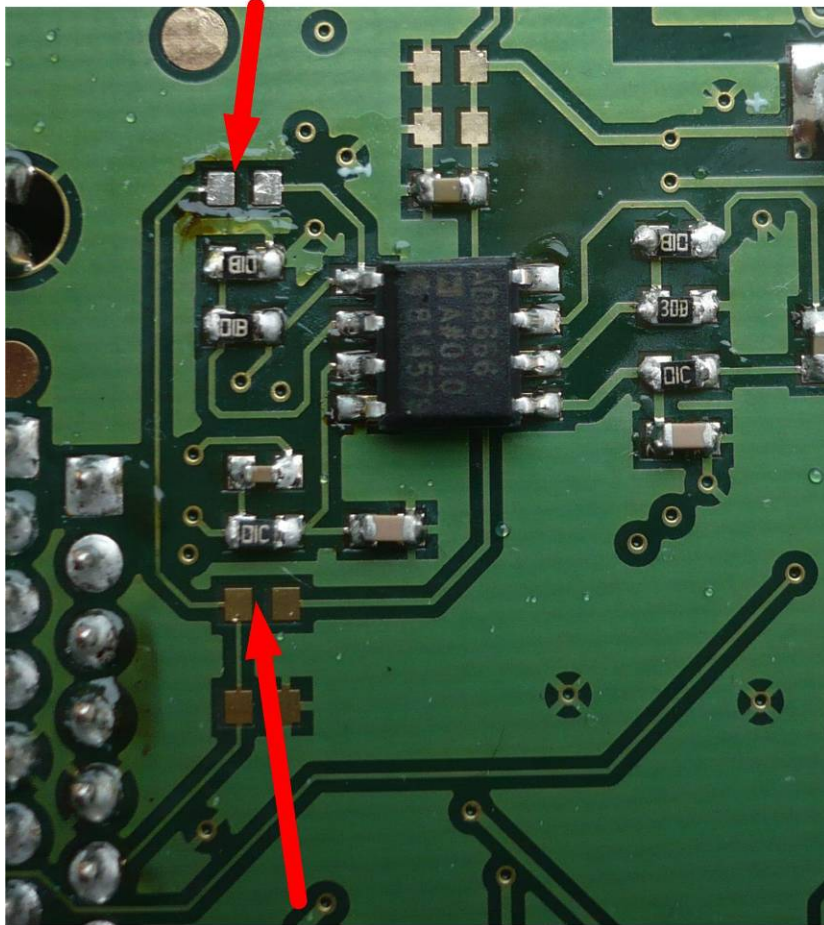

Figure 12: Location of the DAC selection resistances

Solder here a 0 Ohms resistor
to use 16 bits DAC



Solder here a 0 Ohms resistor
to use 10 bits DAC

Figure 13: Location of the DAC select resistances

In this chapter user can find the identifiers of the different connectors used in the i116 motor controller.

The table below shows the manufacturer and manufacturer identifier of all the connectors used on the i116 board. Possible mating connectors for all of them are also shown.

Connector ID	Socket Connector Manufacturer	Socket Connector Manufacturer id.	Plug connector manufacturer	Plug connector manufacturer id
J1	Tyco	1-1705950-1	Tyco	5-641337-4
J2	Tyco	1-1705950-1	Tyco	5-641337-4
J3	Multicomp	SPC15293	ITT Cannon	ZDAA26P
J5	Phoenix contacts	1757284	Phoenix contacts	1757051
P1	Multicomp	5504F1-15S-01-03-F1	Multicomp	5501-09PA-02-F1

Table 20: Connectors of i116 motor controller